

“Las Tecnologías” libro caligrafix matemáticas pag 143.

Martes 2 de Noviembre

NOMBRE: \_\_\_\_\_



DÍA









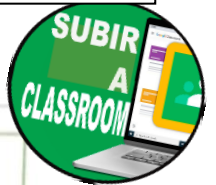

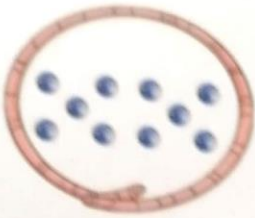
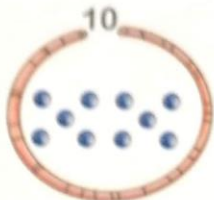

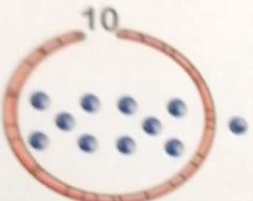
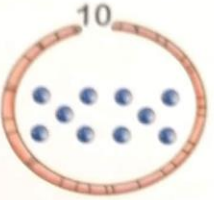
MES

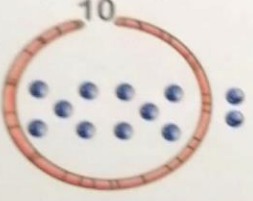
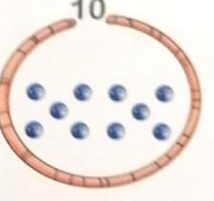
ÁMBITO: INTERACCIÓN Y COMPRENSIÓN DEL ENTORNO

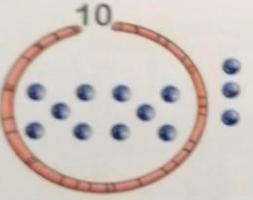
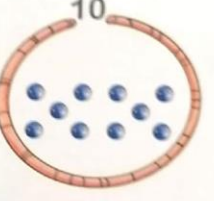
NÚCLEO: PENSAMIENTO MATEMÁTICO

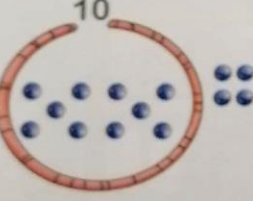
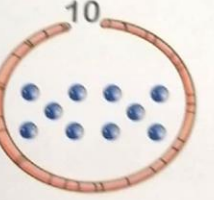
OBJETIVO DE LA ACTIVIDAD: Resolución de problemas matemáticos, con elementos pictográficos y concretos

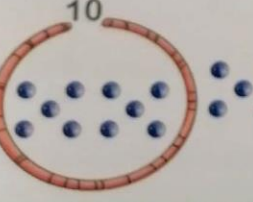
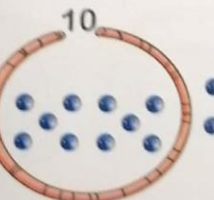

	=	<input type="text"/>			=	<input type="text"/>
	=	<input type="text"/>			=	<input type="text"/>
	=	<input type="text"/>			=	<input type="text"/>
	=	<input type="text"/>			=	<input type="text"/>
	=	<input type="text"/>			=	<input type="text"/>
	=	<input type="text"/>			=	<input type="text"/>

Decenas y unidades

• Escribe el número que se forma en cada caso. Cuenta desde el 10.

Caligrafix 

143